

S-8016.B5

COVERED ARC WELDING ELECTRODE
FOR 0.5%Cr-1.0%Mo HEAT RESISTANT STEEL

2020.12

HYUNDAI WELDING CO., LTD.



❖ Specification

AWS A5.5	E8016-B5
ISO 3580-B	E5518-C1M

❖ Applications

S-8016.B5 is a low hydrogen type covered electrode for 0.5%Cr-1.0%Mo Heat resistant steel. The electrode is suitable for all-position welding in plate and pipes and Good performance by AC/DCEP current.

❖ Characteristics on Usage

Welding of 0.5% Cr-1.0% Mo steels used for electric power and high pressure vessel.

❖ Note on Usage

1. Dry the electrodes at 350°C ~ 400°C (662 ~ 752°F) for 60 minutes before use.
2. Keep the Arc as short as possible, and avoid large width weaving.
3. Adopt back step method or strike the Arc on a small steel plate prepared for this particular purpose to prevent blow-holes at the Arc starting.
4. Preheat at 100-150°C (212~302°F). The temperature to be applied varies in accordance with plate thickness and kind of steel to be welded



Mechanical Properties & Chemical Compositions of All Weld Metal

❖ Welding Conditions

Method by AWS Spec.

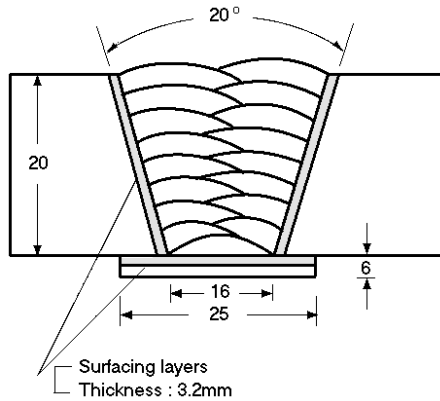

Diameter, : 4.0 X 400mm(5/32 X 16in)

Amp./ Volt. : 170 / 23~25

Interpass Temp. : 200 ~ 315°C(392~599°F)

Polarity : AC

[Joint Preparation & Layer Details]

❖ Mechanical Property of All Weld Metal

Consumable	Tensile test			PWHT	
	YS MPa (lbs/in ²)	TS MPa (lbs/in ²)	EL (%)	Temp. °C(°F)	Time
S-8016.B5	555 (80,600)	663 (96,300)	27.8	690(1274)	1hr
AWS A5.5	≥460 (≥67,000)	≥550 (≥80,000)	≥19	690(1274)	1hr

❖ Chemical Composition of All Weld Metal(wt%)

Consumable	Chemical Compositions (wt%)						
	C	Si	Mn	P	S	Cr	Mo
S-8016.B5	0.10	0.48	0.59	0.019	0.009	0.51	1.00
AWS A5.5	0.07 ~0.15	0.30 ~0.60	0.40 ~0.70	0.030 max	0.030 Max	0.4 ~0.6	1.00 ~1.25

This information is provided solely for the purpose of confirming product conformance with applicable standards. The serviceability of a product or structure utilizing this type of information is and must be the sole responsibility of the builder/user. Many variables beyond the control of HYUNDAI WELDING CO., LTD. affect the results obtained in applying this type of information. These variables include, but are not limited to, welding procedure, shielding gas, plate chemistry and temperature, weldment design, fabrication methods and service requirements.



Weldability & Welding Efficiency

❖ Weldability

Item	Division	Flat position	Vertical position
	Arc stability		Excellent
Melting rate		Excellent	Excellent
Deposition rate		Excellent	Excellent
Resistance of spatter occurrence		Excellent	Excellent
Bead appearance		Good	Good
Slag detachability		Good	Good

❖ Test Conditions of Deposition Efficiency

Consumable	Base Metal		Welding conditions		
	Specification	Dimension (mm)	Amp. (A)	Welding speed (mm/min)	Position
S-8016.B5 (4.0 x 400 mm) (5/32 x 16 in)	ASTM A36	300 X 100 X12 (12 X 3.9 X 0.5)	170 ~180	200	Flat

❖ Results of Deposition Efficiency Test

Consumable	Deposition efficiency (%)	
	For electrode	For core wire
S-8016.B5 (4.0 x 400 mm) (5/32 x 16 in)	65 ~ 70	110 ~ 120

This information is provided solely for the purpose of confirming product conformance with applicable standards. The serviceability of a product or structure utilizing this type of information is and must be the sole responsibility of the builder/user. Many variables beyond the control of HYUNDAI WELDING CO., LTD. affect the results obtained in applying this type of information. These variables include, but are not limited to, welding procedure, shielding gas, plate chemistry and temperature, weldment design, fabrication methods and service requirements.



Diffusible Hydrogen Contents & Proper Welding conditions

❖ Diffusible Hydrogen Contents of Weld Metal

Consumable	Welding current	Diffusible hydrogen contents (ml/gr. Weld metal)					Test method
		X ₁	X ₂	X ₃	X ₄	Avg.	
S-8016.B5 (4.0 x 400 mm) (5/32 x 16 in)	AC 180 Amp.	6.88	6.72	7.00	6.90	6.88	Gas Chromatograph

Average Hydrogen Content **6.88 ml/100g Weld Metal**

❖ Sizes Available and Recommended Currents

Diameter, mm(in)		2.6 (3/32)	3.2 (1/8)	4.0 (5/32)	5.0 (3/16)	6.0 (15/64)
Length, mm(in)		350(14)	400(16)	400(16)	450(18)	450(18)
Recommended current range (AC or DC+ Amp.)	Flat (1G-PA)	55 ~ 90	90 ~ 130	130 ~ 190	190 ~ 240	250~300
	3G (PF) & 4G,5G (PE)	50 ~ 80	80 ~ 120	120 ~ 170	-	-

This information is provided solely for the purpose of confirming product conformance with applicable standards. The serviceability of a product or structure utilizing this type of information is and must be the sole responsibility of the builder/user. Many variables beyond the control of HYUNDAI WELDING CO., LTD. affect the results obtained in applying this type of information. These variables include, but are not limited to, welding procedure, shielding gas, plate chemistry and temperature, weldment design, fabrication methods and service requirements.